

物件名 耐力壁加力試験システム(4間タイプ)		
図面名 A-1	設計者	日付

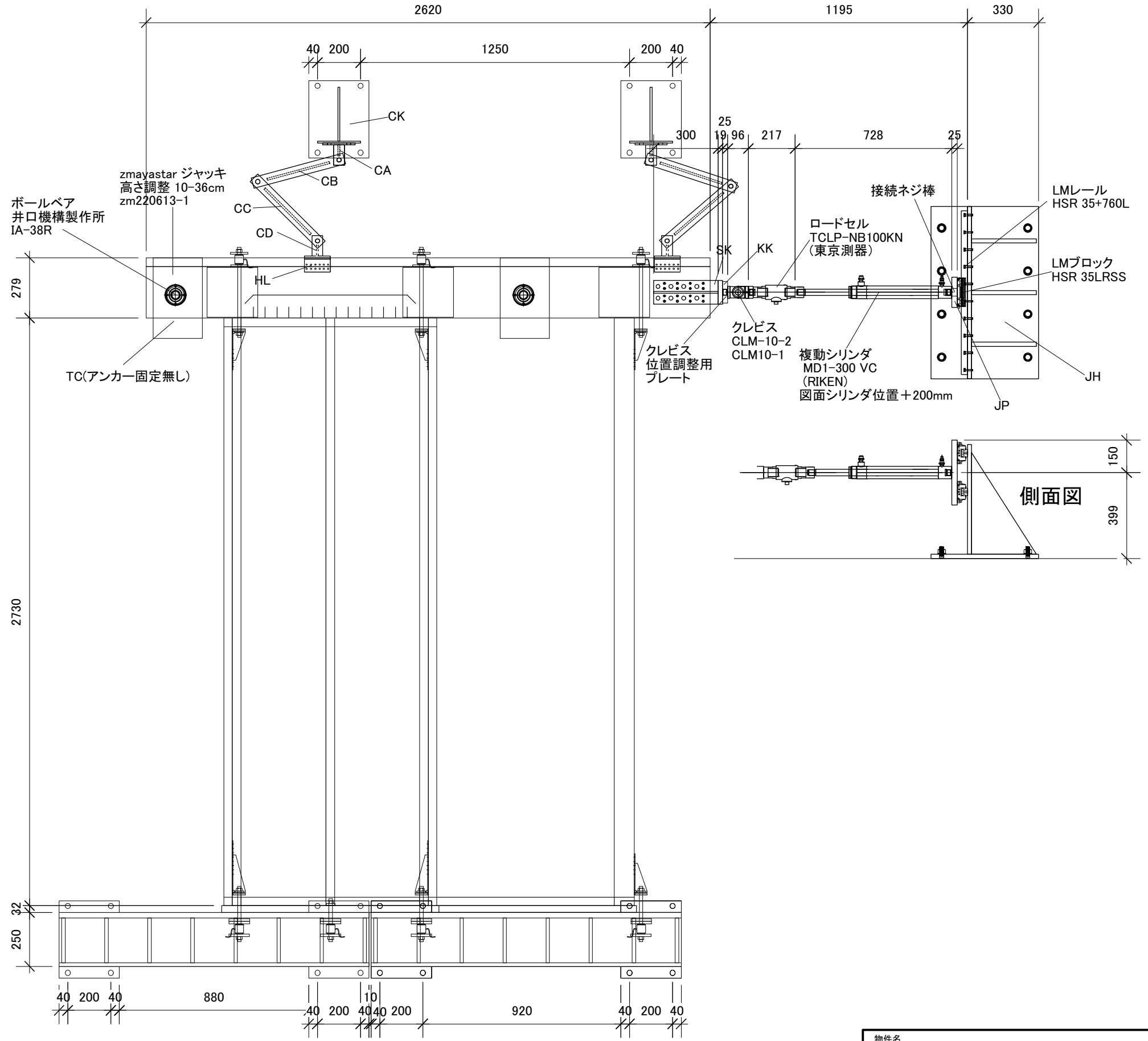

物件名 耐力壁加力試験システム(2間タイプ)		
図面名 A-2	設計者	日付

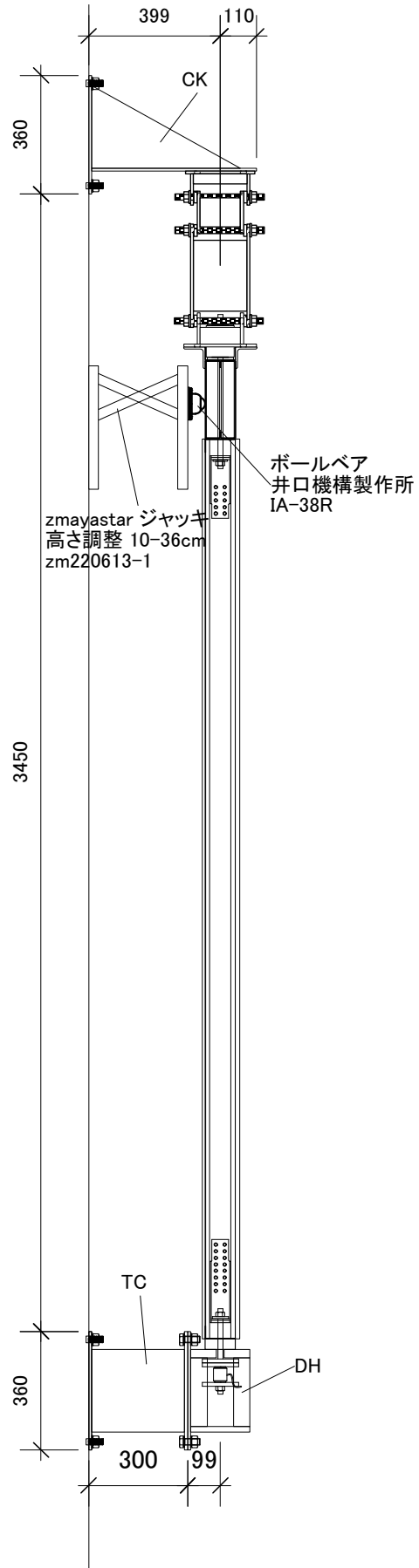
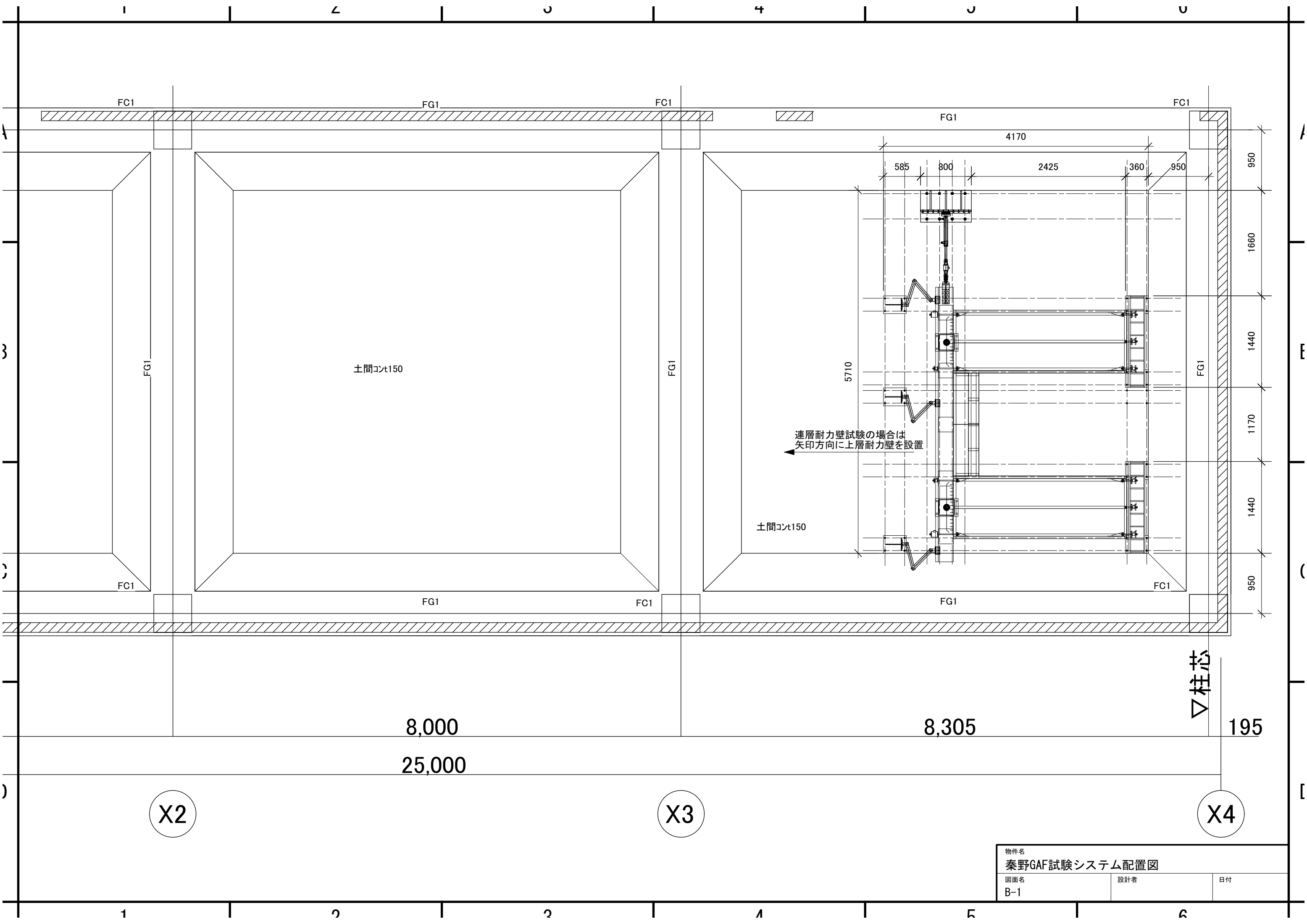

X2

X3

X4

物件名 秦野GAF試験システム配置図		
図面名 B-1	設計者	日付

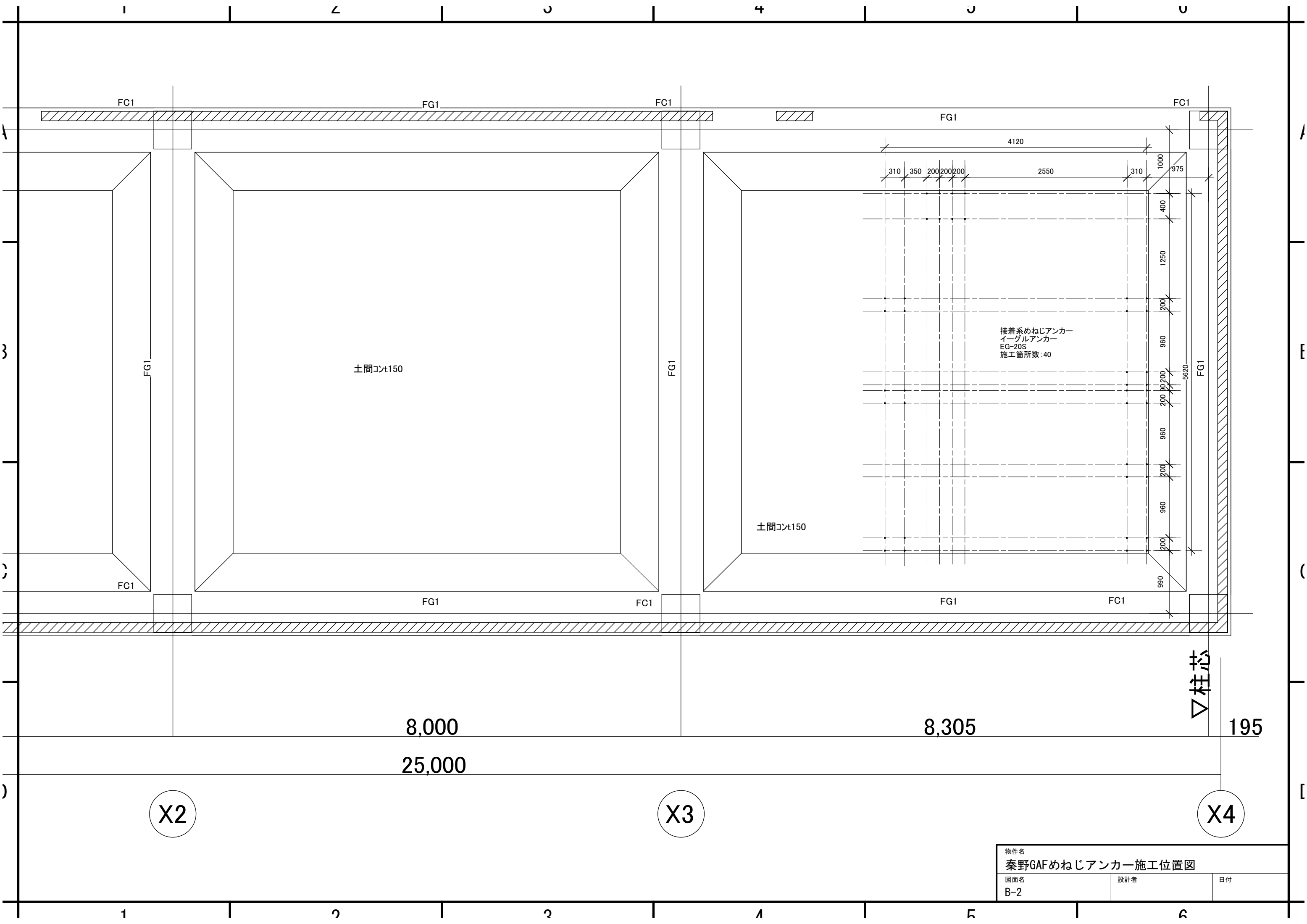

FC1

FG1

FC1

FC1

FG1

4120

310 350 200 200 200

2550

310

1000

975

400

1250

200

960

400

200

960

200

960

200

990

FG1

▽柱芯

195

土間コンt150

土間コンt150

8,000

8,305

25,000

X2

X3

X4

物件名 秦野GAFめねじアンカー施工位置図		
図面名 B-2	設計者	日付

1

2

3

4

5

6

I

J

K

L

M

N

3

2

1

A

E

C

B

6

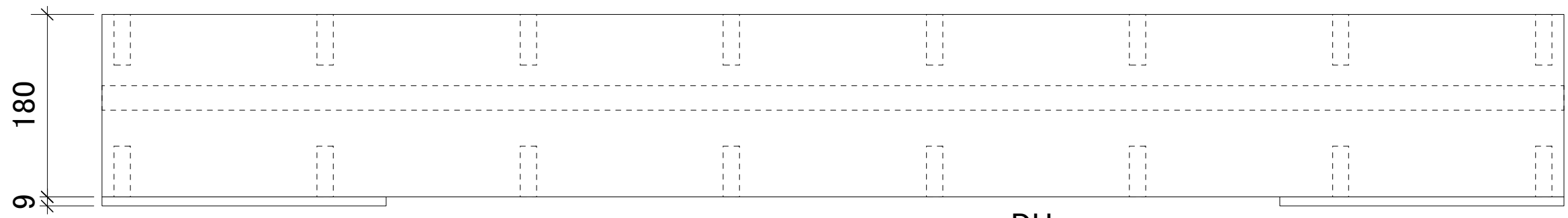
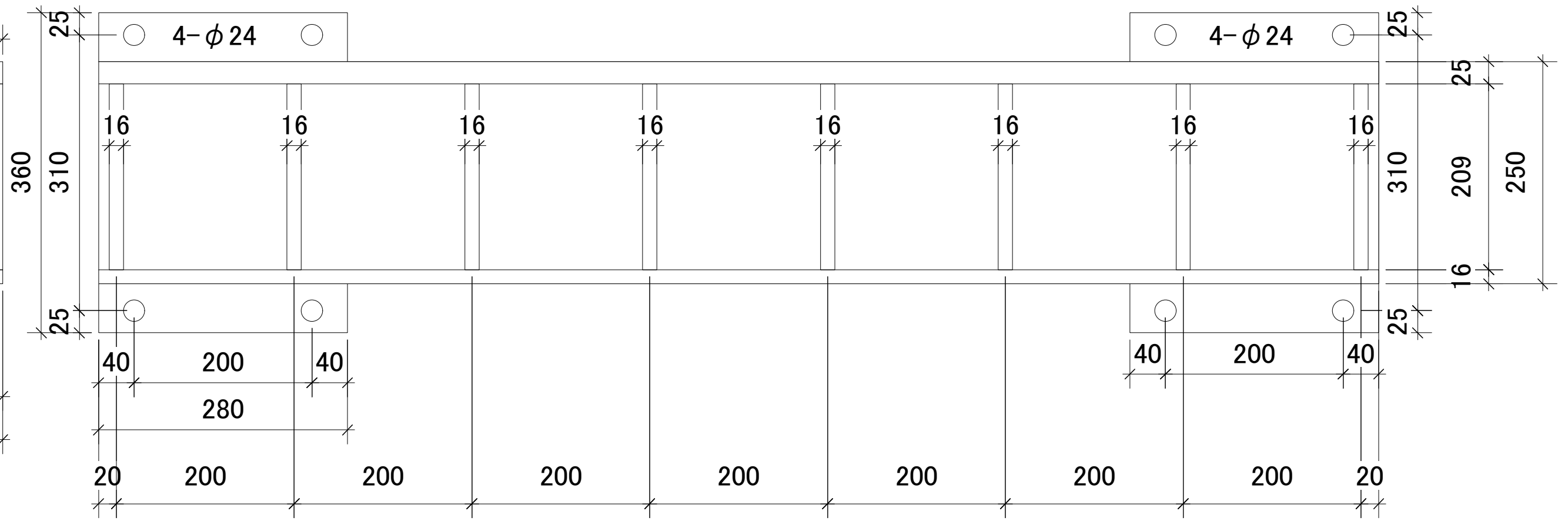
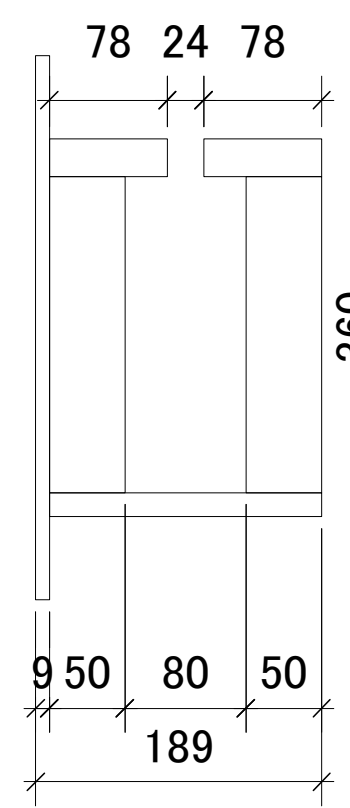
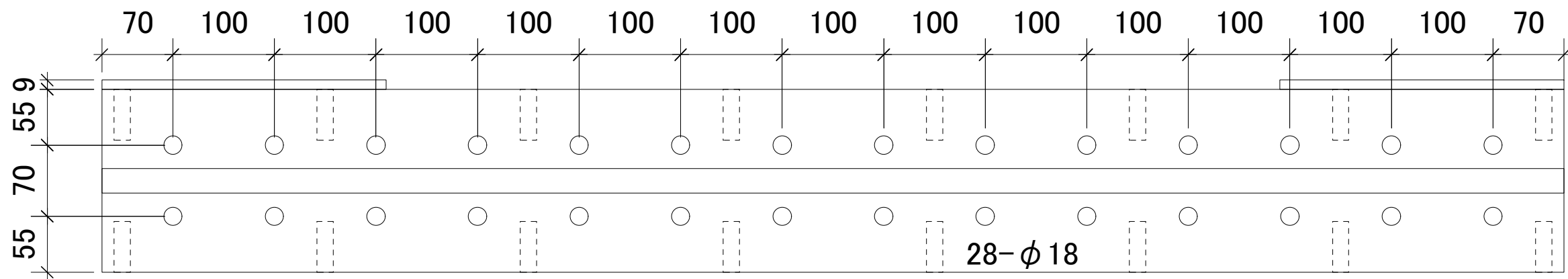

DH
 数量:2
 一般用錆止めペイント

全て隅肉溶接
 鋼材:SS400級

物件名 鋼製土台		
図面名 C-1	設計者	日付

1

2

3

4

5

6

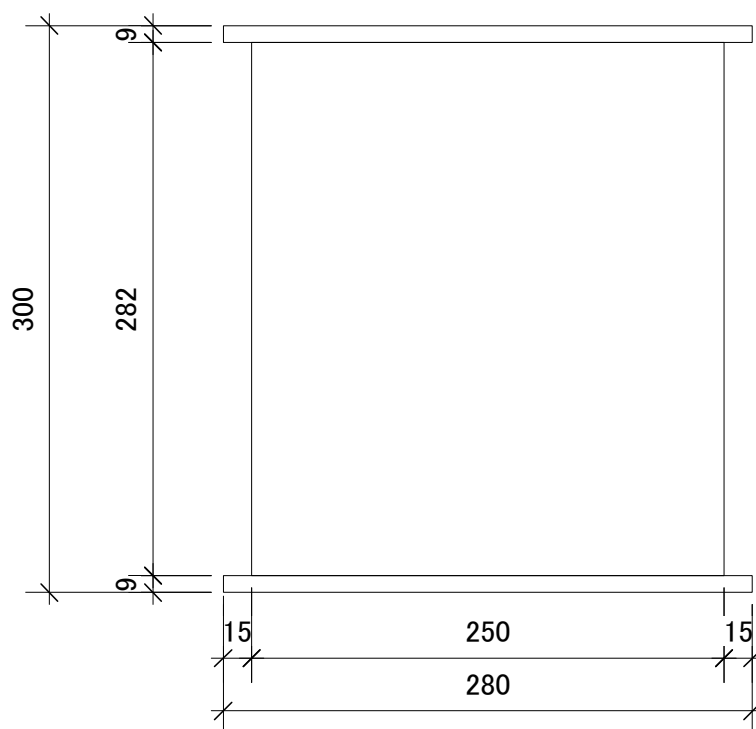
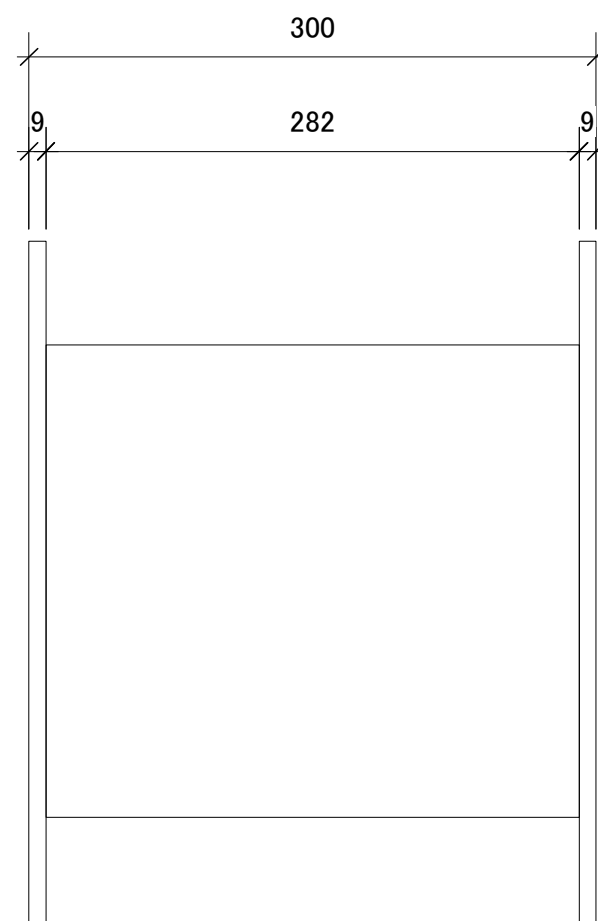
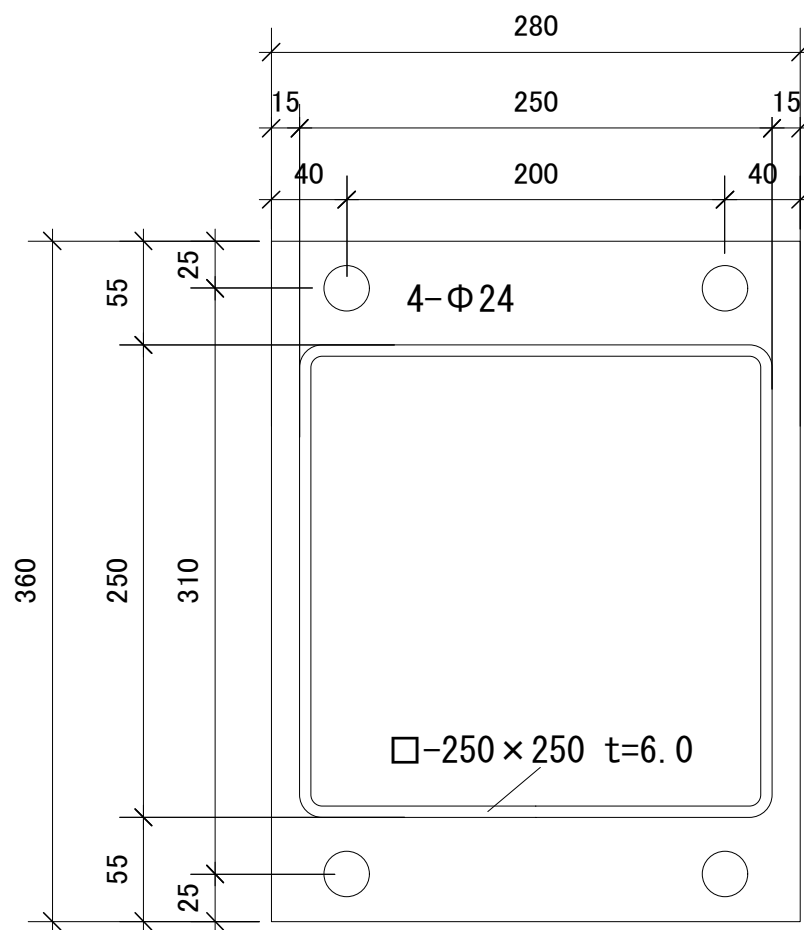

TC(高さ調整柱)
 数量: 4
 鋼材: SS400級
 一般用錆止めペイント

物件名 高さ調整柱		
図面名 C-2	設計者	日付

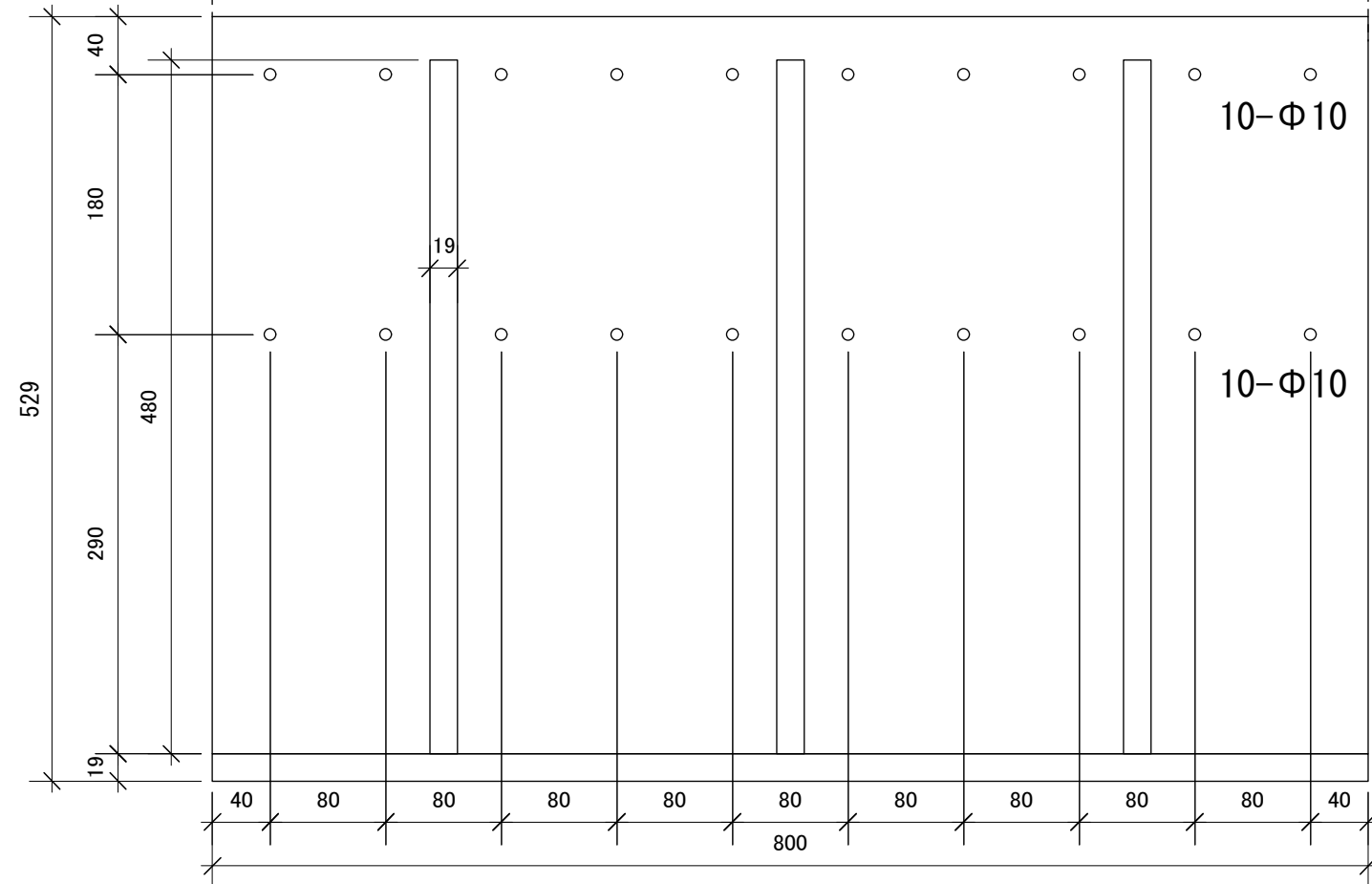
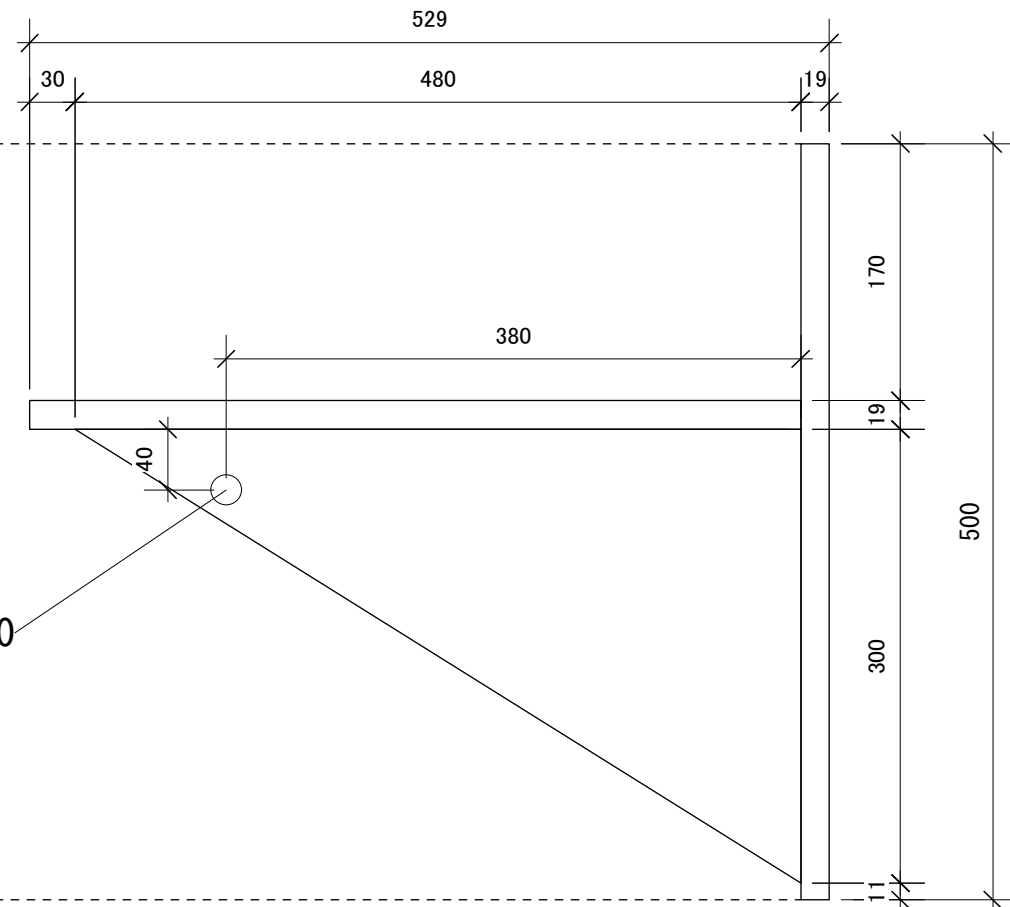
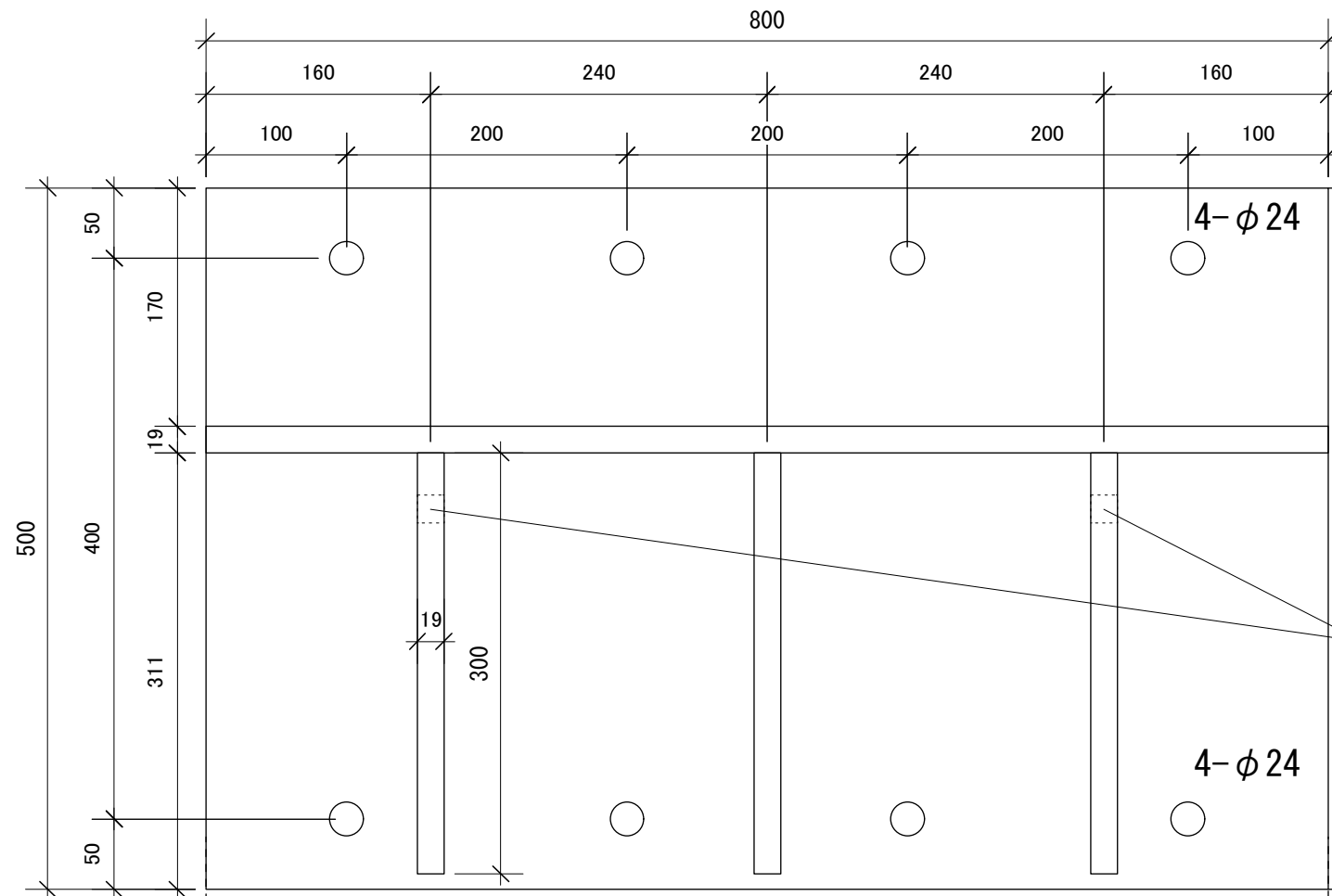

JH(ジャッキ反力台)
 一般用錆止めペイント
 数量:1

全て隅肉溶接
 鋼材:SS400級

物件名 ジャッキ反力台		
図面名 C-3	設計者	日付

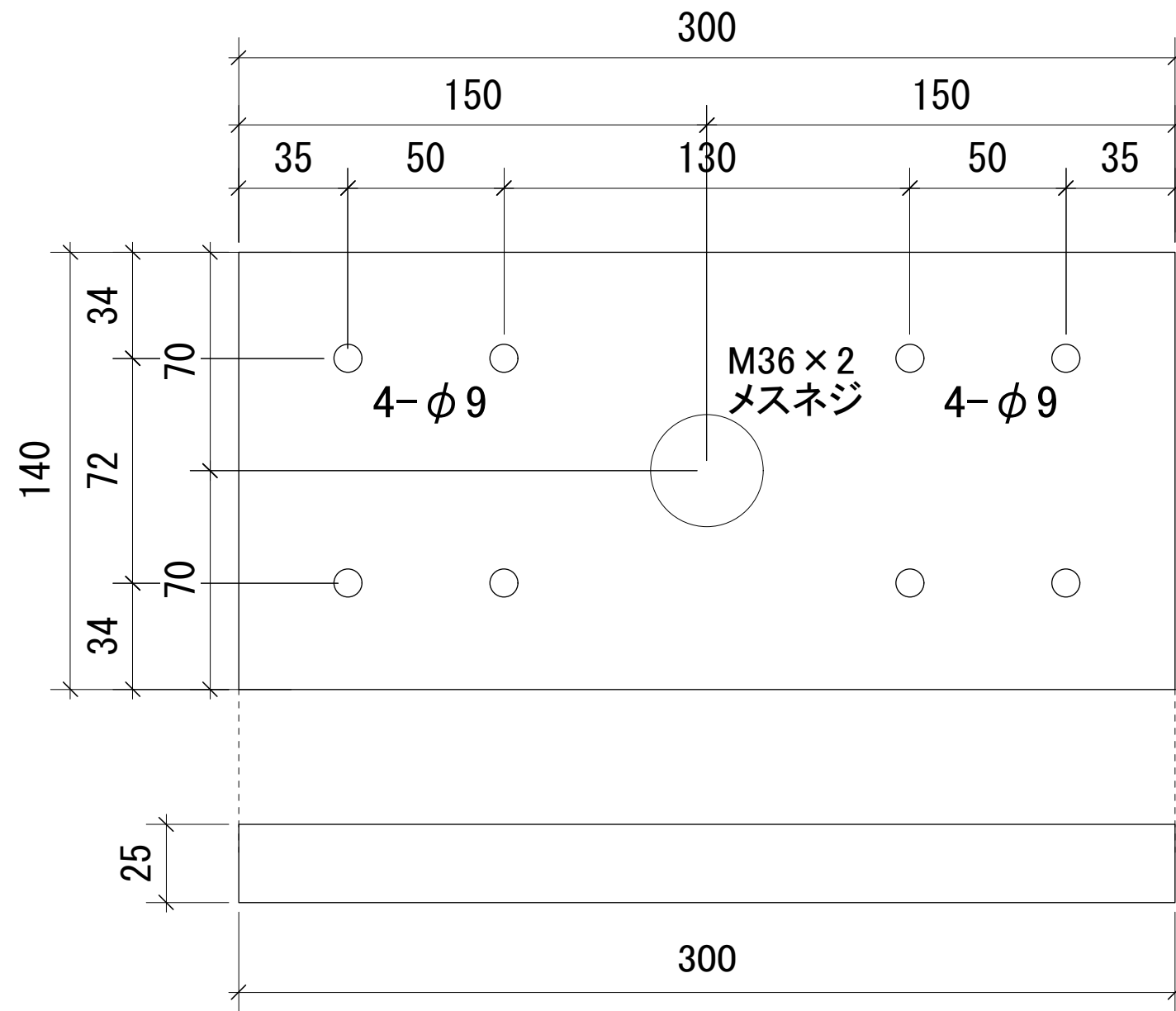

部材名: JP
 数量: 1
 鋼材: SS400級
 一般用錆止めペイント

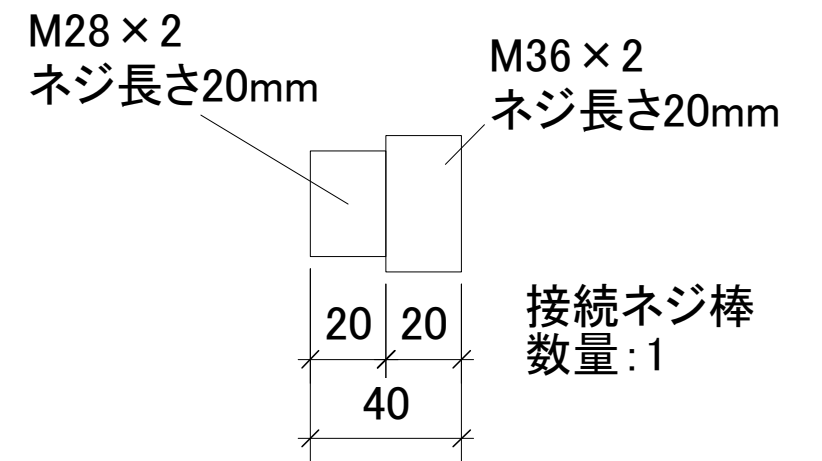

物件名 ジャッキ接合部材		
図面名 C-4	設計者	日付

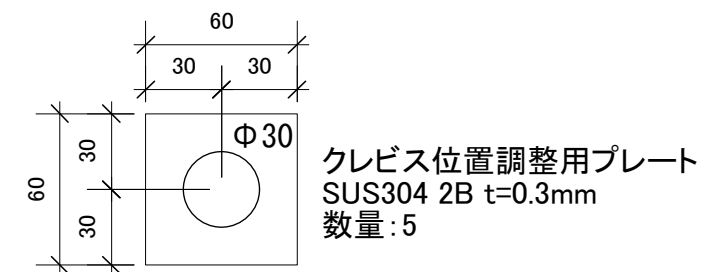
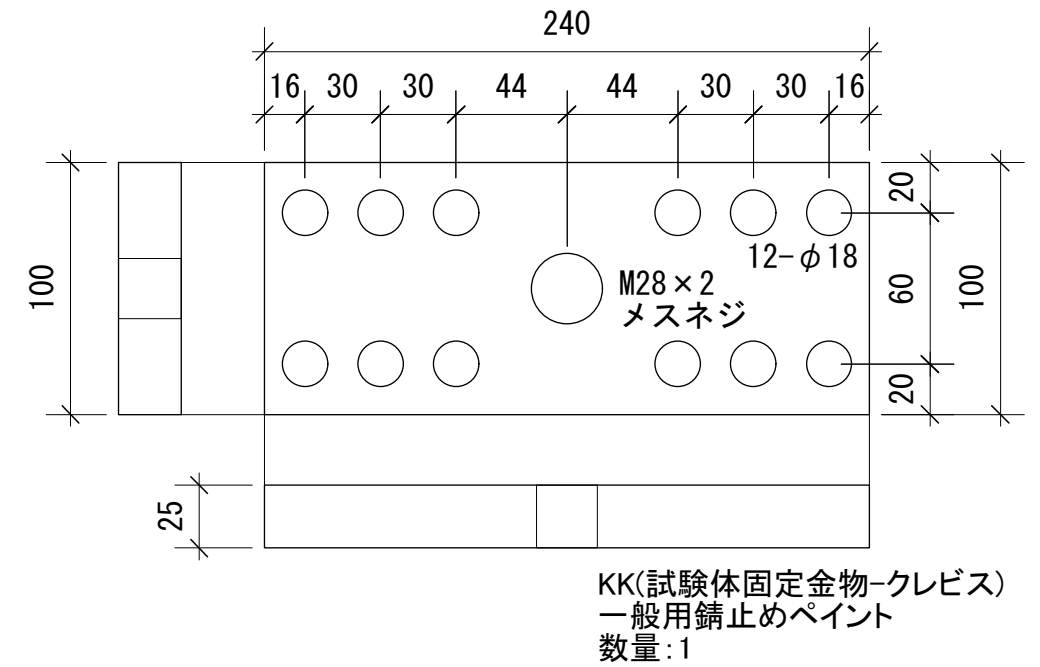
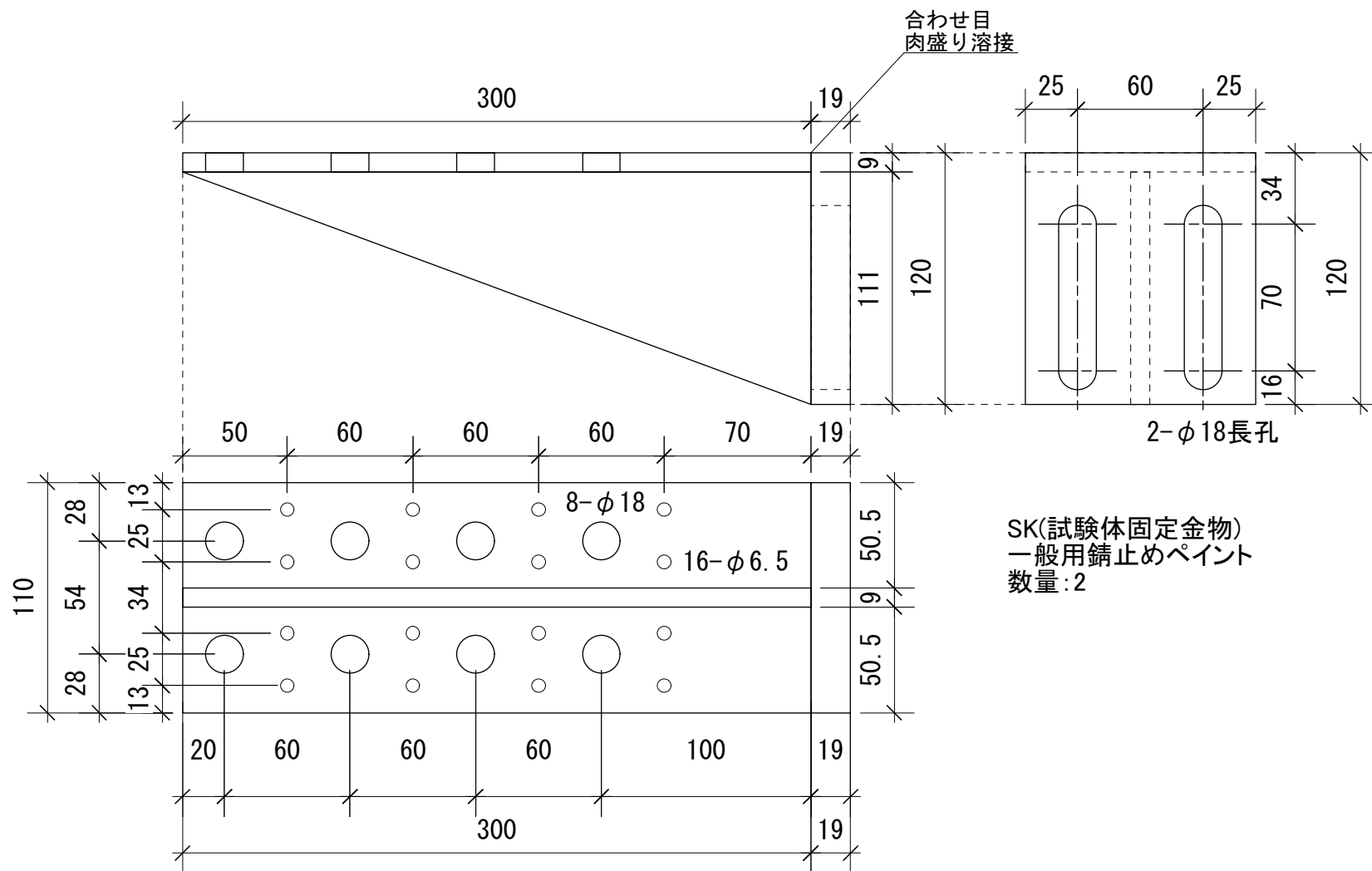

全て隅肉溶接
鋼材: SS400級

物件名 試験体固定金物		
図面名 C-5	設計者	日付

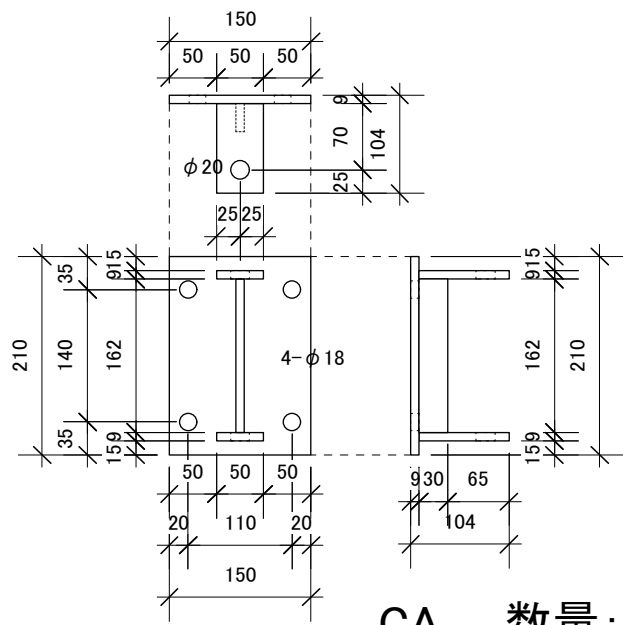

CA 数量:3

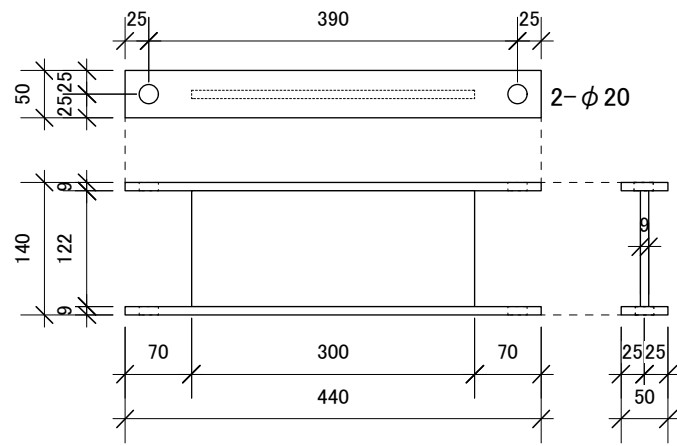

CB 数量:3

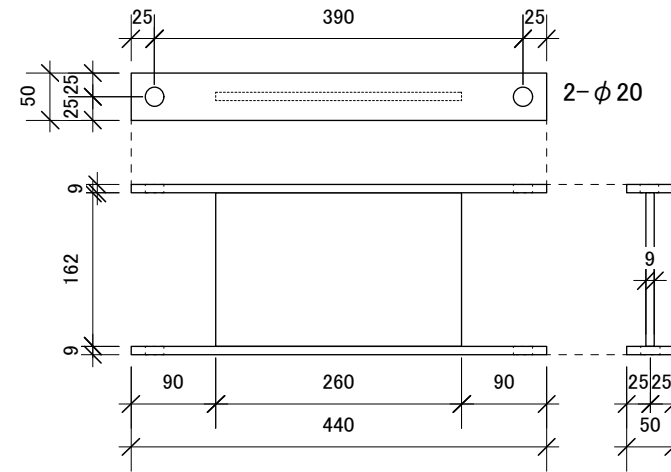

CC 数量:3

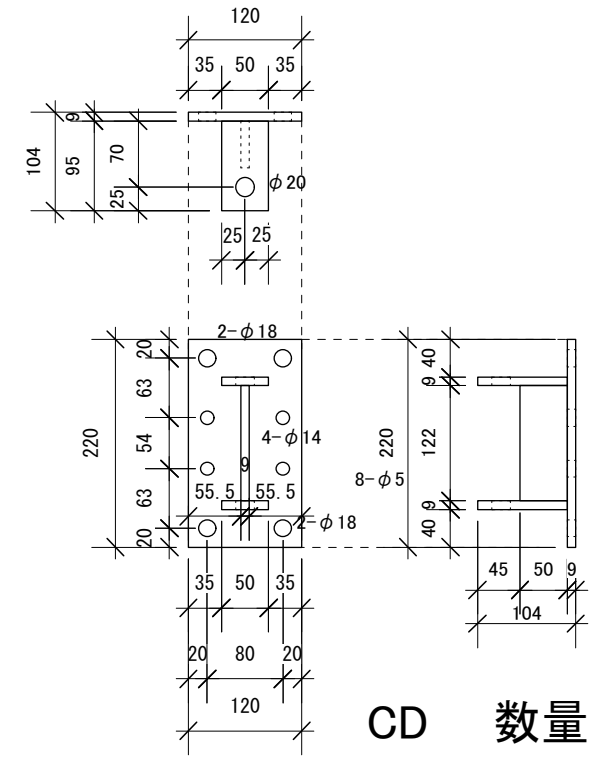

CD 数量:3

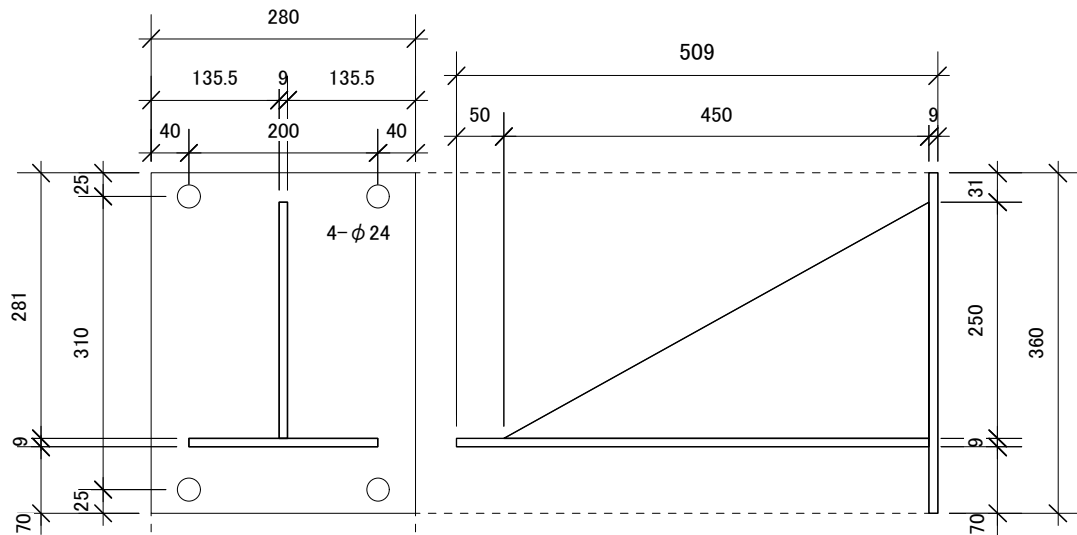

CK 数量:3

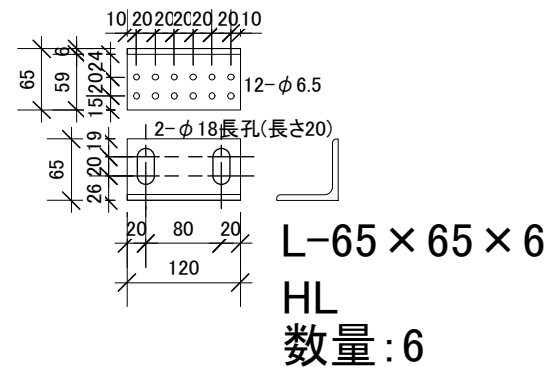
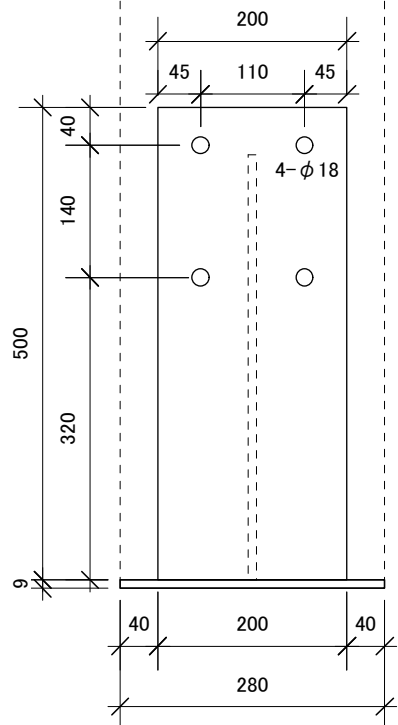

ねじ切り加工
M20×2.5(並目)

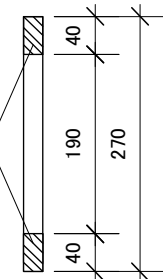

クランク機構
ピン棒φ20 数量9

全て隅肉溶接
一般用錆止めペイント
鋼材:SS400級

物件名 面外変形拘束治具		
図面名 C-6	設計者	日付